



# RESIDENTIAL GAS NON-CONDENSING POWER VENT



## Versatile Power Vent Design

- All models feature an exclusive 3-position rotatable blower outlet which adds flexibility.
- Combined horizontal and vertical vent runs up to 180 equivalent feet with 4" diameter venting (ABS, PVC, CPVC and polypropylene).
- All models are equipped with a protected sensor that detects the presence of flammable vapors and automatically disables the burner to prevent ignition.
- Air intake snorkel elevates the inlet location of combustion air to prevent flammable vapors from entering the sealed combustion chamber.

## Hot Surface Ignitor

- More robust and reliable than standing pilot, and reduces energy consumption

## Built-in Heat Traps on the Water Inlet and Outlet Reduce the Amount of Heat Lost Through Piping

## 2-inch, Thick, "Environmentally-Friendly" Foam Insulation Reduces the Amount of Heat Loss and Contributes to Overall Energy Efficiency

## User-Friendly

- State-of-the-art electronic gas control provides more precise temperature control.
- LED control light displays operation status and diagnostics information.

## Enhanced-Flow Brass Drain Valve Available in Natural Gas and Propane

### Code Compliance

- Meets UBC, CEC and HUD National Codes.
- Meets the thermal efficiency and standby loss requirements of the U.S. Department of Energy and current edition of ASHRAE/IESNA 90.1.
- Complies with the Federal Energy Conservation Standards effective April 16, 2015, in accordance with the Energy Policy and Conservation Act (EPCA) as amended.

## Design-Listed by CSA International

- Certified at 300 PSI test pressure and 150 PSI working pressure.
- Listed according to ANSI Z21.10.1-CSA 4.1 standards governing storage tank-type water heaters.

## 6-Year Limited Tank and Parts Warranty

- For complete information, consult written warranty or go to hotwater.com.

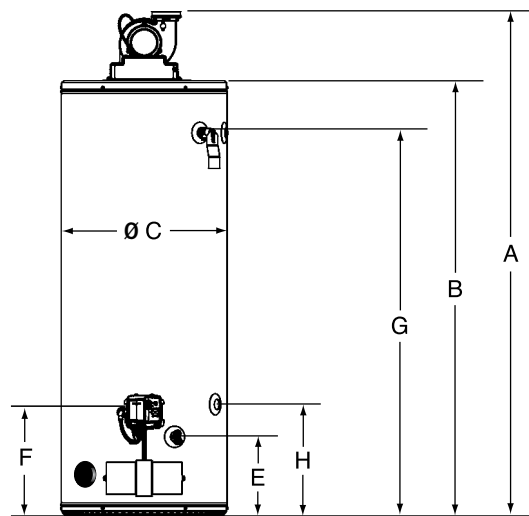
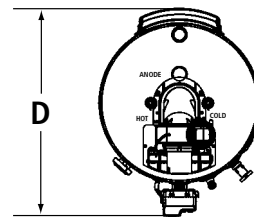

Model Number	Series	Gallon Capacity	Energy Factor (EF)	Recovery @ 90°F Rise Gallon Per Hour	BTU Input Gallon Per Hour	First Hour Rating	Approx. Shipping Weight (lbs)
GPVL-40	200	40	0.70	44.7	40,000	73	174
GPVT-40	200	40	0.70	55.9	50,000	90	176
GPVL-50	200	50	0.70	44.7	40,000	90	198
GPVT-50	200	50	0.70	55.9	50,000	96	192
GPVX-50L	200	50	0.70	69.3	62,000	110	212
†GPVX-75L	210	75	N/A	80.4	76,000	N/A	277

Model Number	Dimensions in Inches							
	A	B	C	D	E	F	G	H
GPVL-40	59	49-5/8	22	29-1/8	11	13-1/4	42-1/2	15-1/4
GPVT-40	68-1/2	59-1/4	20	27-1/8	11	13-1/4	53-1/8	15-1/4
GPVL-50	60-1/8	50-3/4	24	31-1/8	11	13-1/4	43-3/4	15-1/4
GPVT-50	68-1/8	58-3/4	22	29-1/8	11	13-1/4	51-3/4	15-1/4
GPVX-50L	61-1/8	52	24	31-1/8	11	13-1/4	44-1/2	15-1/4
†GPVX-75L	70-5/8	61-1/4	26	33-1/8	11	13-1/4	53	15-1/4

Available in propane (LP) gas. Specify when ordering propane (LP) gas.

Side connections are standard on GPVX models.

Side connections available on GPVT models. Add "L" to the model number (example: GPVT-40L).

All models are certified from sea level to 10,100 ft. elevation.

† GPVX-75L is not ENERGY STAR® Qualified.

